

Surface Mount Type

■ Packaging Specifications

● Reel Dimensions in mm (not to scale)

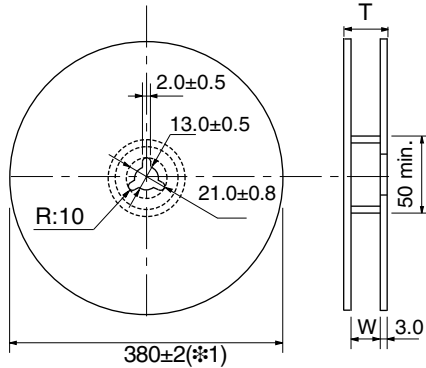

Size	W
A, B, C	14±1
D, E, D8	18±1
F, G	26±1

Size	W	mm
G13 to G21	34±1	
H13 to H21		
J16 to J21	46±1	
K16 to K21		

(※1)330mm(13 inch)reel is available on request.(code:A)

Size code	Height	Min.Packing Quantity pcs	
		380mm reel	330mm reel
A, B	L=5.4mm	2000	1500
	L=5.8mm	2000	1200
C, D	L=5.4mm	1000	1000
	L=5.8mm	1000	800
E	-	1000	800
D8	-	900	500
F, G	-	500	300
B, C	L=4.5mm	2000	1500
D	L=4.5mm	1000	1000

Size code	Min Packing Quantity pcs
	330mm reel
G13	250
G17, H13	200
G21, H16	150
H21, J16, K16	125
J21, K21	75

● Taping Dimensions in mm(size A to G)

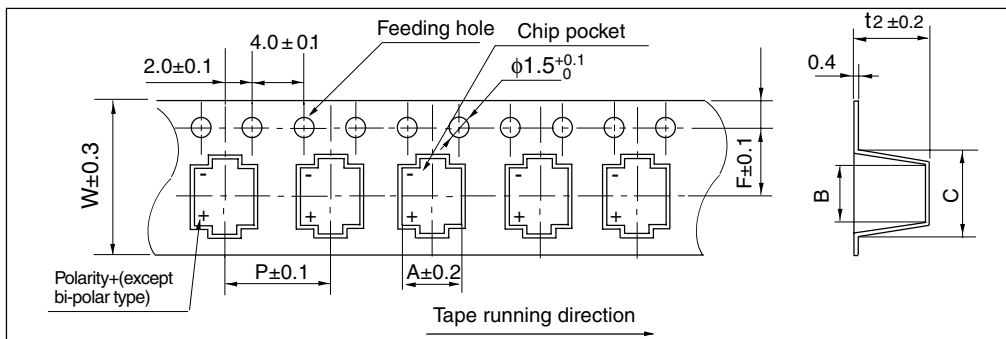

Ask factory for technical specifications.

Size code	W	A	B	C	P	F	t 2		
							Height		
							L=4.5mm	L=5.4mm	L=5.8mm
A	12.0	3.4	3.5±0.2	6.0±0.3	8.0	5.5	-	5.8	-
B	12.0	4.7	4.6±0.2	6.5±0.3	8.0	5.5	4.9	5.8	6.2
C(※2)	12.0	5.7	5.7±0.3	8.0±0.5	12.0	5.5	4.9	5.8	6.4
D	16.0	7.0	7.0±0.3	9.0±0.5	12.0	7.5	4.9	5.8	6.4
D8	16.0	7.0	7.0±0.3	9.0±0.5	12.0	7.5	8.4		
E	16.0	8.7	8.7±0.3	11.4±0.5	12.0	7.5	6.8		
F	24.0	8.7	8.7±0.3	12.5±0.5	16.0	11.5	11.0		
G	24.0	10.7	10.7±0.3	14.5±0.5	16.0	11.5	11.0		

(※2) Height L=4.5mm P=8.0

● Taping Dimensions in mm(size G13 to K21)

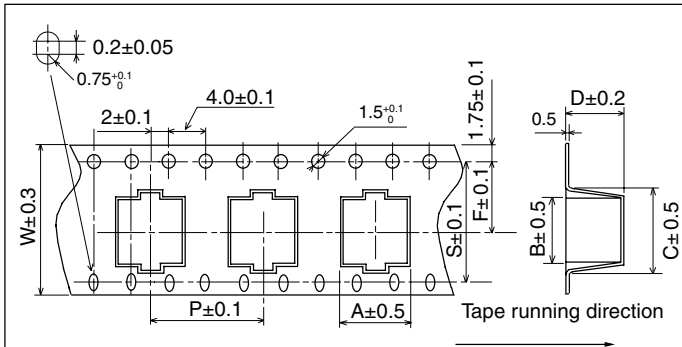

Ask factory for technical specifications.

Size	Taping Size							
	A	B	C	D	F	P	S	W
G13	10.7	10.7	14.5	14.5	14.2	20.0	28.4	32.0
G17	10.7	10.7	14.5	17.5	14.2	20.0	28.4	32.0
H13	14.0	14.0	18.0	17.5	14.2	24.0	28.4	32.0
H16	14.0	14.0	18.0	17.5	14.2	24.0	28.4	32.0
J16	17.5	17.5	23.0	17.5	20.2	28.0	40.4	44.0
J21	17.5	17.5	23.0	22.5	20.2	28.0	40.4	44.0
K16	19.5	19.5	26.0	17.5	20.2	32.0	40.4	44.0
K21	19.5	19.5	26.0	22.5	20.2	32.0	40.4	44.0